

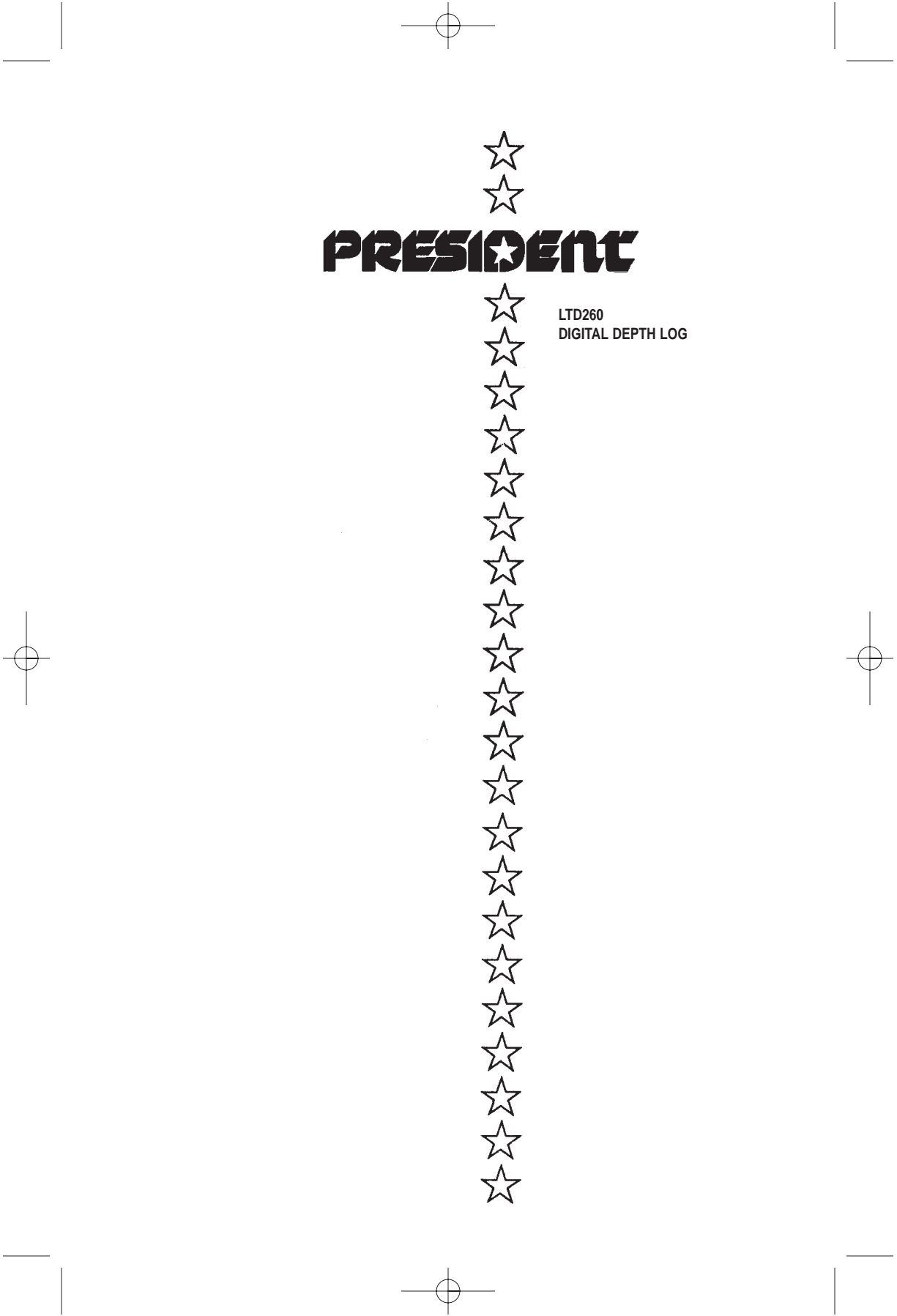

LTD260  
DIGITAL DEPTH LOG



## Digital Depth Sounder

LTD 260

TO OUR CUSTOMER:

We would like to extend our thanks to you for purchasing the LTD 260. This product is a highly sophisticated instrument which is designed using the criteria "simplicity of operation".

It is very important that you review this manual carefully and thoroughly prior to using your President instrument. Successful instrument operation can be achieved with proper installation, background education, and a thorough understanding of how the equipment operates.

Your LTD 260 is an aid to navigation and does not reduce the need for caution or judgment. No electronic navigation system is absolutely reliable; outputs may occasionally be incorrect. The careful navigator should never rely solely on one device, to the extent of endangering life or property. Please remember that any time a display reading flashes on and off, the outputs may be in error and should not be used for navigation. We recommend that you use this system in combination with marine charts, and knowledge of the area where your are boating.

Again, we want to thank you for purchasing a President product and are confident of your satisfaction.

Sincerely,  
PRESIDENT

PRESIDENT, 4700 Amon Carter Blvd., Fort Worth, TX 76155, USA, Phone (817) 858-3300

**GENERAL OVERVIEW:**

This manual has been arranged in the sequence outlined below. This overview below will provide you with a correct sequence of events required to successfully install and operate your instrument.

INSTALLATION:	WIRING .....	4
INSTALLATION:	LTD 260 .....	4
GENERAL INFORMATION:	DEPTH SOUNDER TRANSDUCER .....	5
INSTALLATION:	POWER SOURCE .....	5
INSTALLATION:	DEPTH TRANSDUCERS .....	7
INSTALLATION:	TRANSOM MOUNT TRANSDUCERS .....	8
INSTALLATION:	THROUGH-THE-HULL TRANSDUCERS .....	9
INSTALLATION:	POWERBOAT BRONZE TRANSDUCERS .....	10
INSTALLATION:	INSIDE THE HULL TRANSDUCERS .....	11
OPERATION:	How to set the alarm .....	12
GLOSSARY	.....	13
TROUBLESHOOTING:	GENERAL OPERATION .....	14
TROUBLESHOOTING:	SHALLOW WATER SENSITIVITY .....	15
CARE AND MAINTENANCE:	.....	17
SPECIFICATIONS:	.....	17
SPARE PARTS LIST:	.....	17
APPENDIX	PRESIDENT LIMITED WARRANTY .....	18
APPENDIX	OUT OF WARRANTY - FLAT RATE CHARGE .....	19

**FEATURES:**

**DEPTH READINGS**

The LTD 260 is designed to give depth readings from 2.5 feet to a maximum depth of 199 feet. Depth readings are in 1/10 foot increments from 2.0 feet to 15 feet and then are shown as whole numbers up to 199 feet. These readings are displayed on a large Liquid Crystal Display (LCD).

**NIGHT VIEWING**

The LTD 260 is back lit at all times with a soft glowing lamp designed to help your night time navigational needs.

**INSTALLATION:** LTD 260

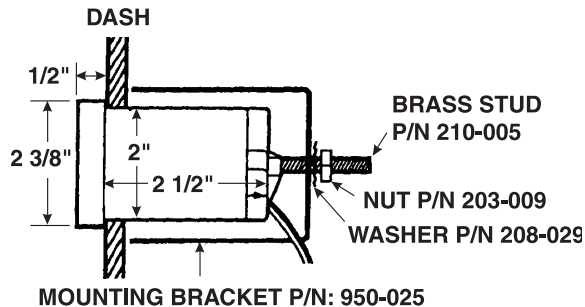

First, find a location on your dash panel which will give clear viewing and access to the LCD window. After finding the right location for the indicator unit, mark a 2 in. hole to be cut out. Check behind the panel for any cables or wiring which could be damaged and then cut out the 2 in. hole. Test fit the unit in the hole and make any adjustments with our saw or drill. Extending out of the back of the instrument, you will notice a brass shaft. First attach the U-shaped mounting bracket over this shaft, place the washer on the shaft and then tighten the nut until the U-shaped bracket presses tightly to the back of the dash panel.. Look at the front of the instrument to ensure that it is aligned properly and then tighten securely.

**INSTALLATION:** WIRING

On the rear of the unit, locate the terminal lugs extending out of the rear of the instrument. These terminal are used to connect the impeller wires.

When shipped from the factory, the transducer is wired with three female lugs attached that need to be inserted into the male terminal located on the rear of the gauge. Exercise caution when installing these connectors since improper wiring of the transducer to the wrong terminals can cause internal damage to the instrument which could cause the unit to fail when power is applied.

BLACK=TRANSDUCER LOW  
 RED=TRANSDUCER HIGH  
 BARE SHIELD=BARE  
 Part Number=703-025  
 (Terminals)

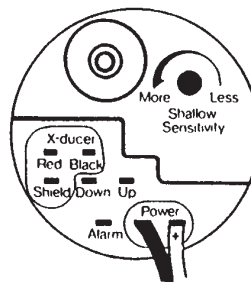

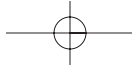

**INSTALLATION:**

**POWER SOURCE**

**BATTERY CONNECTION/POWER REQUIREMENT**

Because the LTD 260 has no ON/OFF switch, you will need to wire it directly to a power source which will turn the unit on as power is applied. It may be a power source which will turn the unit on as power is applied. It may be convenient to wire the power cable directly to the Ignition Switch so that when you turn the boat on, the depth sounder immediately starts working. Some boats have already been prewired and labeled for a depth sounder so that when the switch is turned ON, the depth sounder receives power.

1. Connect the main unit to a 12 volt battery using the power cable supplied with your unit. You may extend this cable as necessary, but you must observe proper polarity (i.E., red is positive, black is negative).
2. Connect the BLACK wire to the negative (-) battery terminal.
3. Connect the RED wire to the positive (+) battery terminal.
4. Make sure the connections are clean and tight so they do not vibrate loose during the boat's operation. Occasionally clean any accumulated corrosion from the battery terminals.
5. If for some reason the fuse is blown, replace with a 1 amp fuse, normal blow.

**DO NOT OVER FUSE!** Because the unit consumes .25 amps of current when it is on, you will want to keep your battery fully charged.

**GENERAL INFORMATION:**

**DEPTH SOUNDER TRANSDUCER**

**UNDERSTANDING SONAR:**

All depth sounders emit Ultra Sonic Sound signals by a transducer into the water located under your boat. These sound signals travel through the water at a rate of 4,800 feet per second. The depth sounder transmits a signal and receives a returning echo. The unit calculates the amount of time in microseconds for the signal to travel to the bottom and return back to the transducer. It then converts this time into depth and displays it on the screen.

It may help to imagine these sound signals bouncing up and down from the transducer to the bottom by comparing it to a ping pong ball bouncing up and down from the floor. The closer the ball is to the floor, the less time it takes for it to return. The higher the ball is bounced, the longer time it takes for it to return. Bouncing a ball off a hard surface such as cement is the same as bouncing a signal off a sandy or hard bottom. Bouncing this same ball off carpeting creates a totally different effect. The ball (echo) returns with less force (weaker echo). The same analogy applies to an echo bouncing on a muddy or grassy bottom - the echoes are weaker.

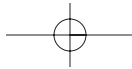

#### AIR ECHOES:

Air echoes can be caused by too much turbulence under the face of the transducer. It is important to know that ultra sonic signals from a transducer will not penetrate air. They react to air in the same manner as they react to a hard bottom described above. Therefore, if your transducer is not mounted properly and you are getting turbulence (air bubbles) under your transducer, you may get false readings simply because signals are being returned by the turbulence and never reaching the bottom.

Adjusting the Shallow Water sensitivity can reduce this problem. Adjustment of the transducer location can also help solve these false readings.

#### TRANSDUCER REPLACEMENT/IDENTIFICATION TAG

On most transducers manufactured after 1987, the operating frequency and part number is attached to the cable or is printed on a mylar tag near the connector end. Do not remove this tag since it identifies the transducer and will help you identify the operating frequency of the transducer. (Improper frequency will cause your instrument to not operate properly.) **Removal of the identification tag will void the warranty.**

#### SALTWATER MAINTENANCE/ANTIFOULING PAINT

Antifouling Paint: If the vessel is kept in saltwater, sea growth can accumulate rapidly on the transducer face and seriously reduce performance in a matter of weeks. If fouling does occur, use a stiff brush or putty knife to remove this growth. Wet sanding of the fouled transducer face is permissible with #220 or finer grade of wet or dry emery paper. (Use plenty of water.) Coating transducers with antifouling paint is often necessary to achieve consistent performance. All anti fouling paints have a solvent base and solvents attack encapsulation materials and plastics to varying degrees. If you need anti fouling protection use only paints with a mineral spirits base; **do not use acetone vinyl based paints.** Gloucester (RULE) 7 is a hard, mineral spirits based paint that we have found to be practically transparent to acoustic energy. Never apply paint to the transducer by spraying; use a brush or roller. A sprayed surface "wets" very slowly and there are often microscopic air pockets under the surface which attenuate the sound energy.

**INSTALLATION:****DEPTH TRANSDUCERS****TRANSDUCER WETTING**

Immediately before your vessel, thoroughly wipe the face of the transducer with a detergent type liquid soap. This reduces the amount of time required for the transducer to establish good contact with the water. If this procedure is not followed it may take several days for the complete "wetting" to occur, resulting in reduced performance of the instrument.

There are a variety of transducers available for use on the many styles of boats available and the preference of the boat owner. The three most popular styles are:

- **TRANSOM MOUNT:** Ideal on boats with outboard engine or on I/O driven boats installed on the stern of the boat)
- **THROUGH THE HULL:** Installation is ideal for boats with Inboard engine(s)
- **INSIDE THE HULL:** Often called Shoot Through Transducer can be used effectively if procedures for installation are followed carefully.

**"STYLE" OF THROUGH-THE-HULL TRANSDUCERS:**

Transducer manufacturers build many different styles of transducers. The two most popular styles of Through the Hull transducers are Low Profile types which typically are 1 3/4" or 2" in diameter of Stem Type transducers which typically have a 3/4" pipe thread and require a fairing block to level it.

**"MATERIAL" OF THROUGH-THE-HULL TRANSDUCERS:**

The two most popular materials used are nylon and bronze.

- **WOODEN BOATS** require the use of a bronze transducer or bronze fittings due to the fact that when the boat is out of the water, the wood will dry out. When the fitting is installed and the boat returned to the water, the wood will swell and possibly crack a nylon type of transducer. Therefore, bronze is recommended for all wooden boat applications.
- **LARGER FIBERGLASS BOATS** often prefer bronze transducers and fittings due to the size of the boat and the total number of fittings used in the installation.

**NYLON OR BRONZE - LOW PROFILE TRANSDUCERS**

Ideal for high speed sport boats and sailboats, this style of transducer is designed to be mounted flush against the hull without a fairing or leveling block. The hull deadrise angle must not exceed 15° in order to use this transducer fitting.

- **SAILBOATS:** Normally a maximum beam amidships or in front of the keel.
- **POWERBOATS:** Off centerline, 6"-12" and before the first lifting strake (flat area). Do not install it on a lifting strake since this is the area where air bubbles travel from the bow to the stern in order to provide a smooth ride.

**INSTALLATION: TRANSOM MOUNT TRANSDUCERS**

**WARNING: DO NOT INSTALL UNDERNEATH A GASOLINE OVERFLOW AS THIS WILL DESTROY THE PLASTIC MATERIAL OF THE TRANSDUCER AND THE BRACKET AND IS NOT COVERED UNDER WARRANTY.** Also, do not use **LOCKTITE** or any similar adhesives on the mounting hardware as these materials also destroy the transducer.

1. Attach the transducer to the bracket as shown.
2. **WEDGE FORWARD:** The style of the transducer with the wedge installed pointing toward the bow is ideal for aluminum hulls, deep-vee hulls, and flat bottom boats. The wedge allows turbulence and water to flow around the face of the transducer and will give high speed performance.
3. Keep the face of the transducer clean and do not paint unless you use paint designed for transducers as described in the section on Transducer Painting.
4. Keep the transducer cable as far away as possible from engines, motors, and other wires.
5. If you leave your boat in the water, follow the instructions for transducer maintenance and/or painting the face of the transducer with transducer paint designed for this purpose.
6. Just before launching your trailerable boat, thoroughly wipe the face of the transducer with a detergent type liquid soap to clean the face of the transducer. This reduces the amount of time required for the transducer to establish good contact with the water.

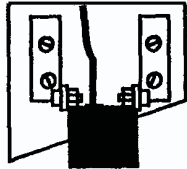

Do not mount on or behind lifting strake

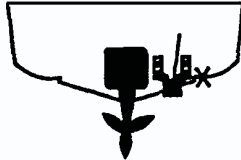
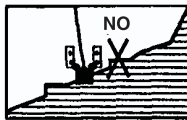

18" to 24" outboard from the centerline before the first lifting strake

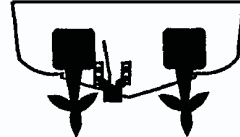

Only practical location for transducer within 6" of centerline

Transducers can be installed on either side, although on single engine boats, the **STARBOARD** (right) side is preferred due to the potential of engine cavitation caused by the rotational pitch of the prop. (i.e. The turbulence caused by the transducer could cause your boat's engine to cavitate if the transducer is on the Port side and the rotation of the prop is clockwise.)

**WARNING: DO NOT PUT UNDER FUEL OVERFLOW!!!**



## INSTALLATION: THROUGH-THE-HULL TRANSDUCERS

In mounting a transducer through the hull (through-hull), it is important that it is done correctly because the location of the transducer on the hull will determine how well the entire unit will perform. There are several factors involved in choosing a good location for a through hull transducer. In general, powerboats should have the transducer mounted in the last 1/2 - 2/3 of the hull below the waterline, but always forward of the props and shafts. Make sure the above guidelines are followed. Sailboats should have the transducer mounted in the first third of the hull below the waterline, if possible about two feet in front of the keel.

### GUIDELINES FOR THROUGH-THE-HULL:

1. The transducer face must always have a smooth flow of water over the face of the transmitting surface. Bubbles will cause the instrument to read improperly and report erroneous readings.
2. Never mount a transducer in direct line or within 4 feet behind another through hull fitting, the keel or rudder, zinc anodes, or other projections that would cause turbulence around the transducer when the boat is under way.
3. Never mount a transducer in a recess or cutaway on the hull so that the face of the transducer is shielded from direct contact with the flow of water.

### INSTALLATION: LOW PROFILE TRANSDUCER

Mount the transducer through-the-hull using the following steps:

1. Drill an 1/8" pilot hole in the preferred transducer location.
2. Drill an appropriate sized hole through the hull using the pilot hole as a guide.
3. Have some type of soft backing plate or thin piece of plywood (3-1/2" x 3-1/2" x 1/2" thick) available to strengthen the inside of the hull around where the hole was drilled. This serves the dual purpose of allowing the transducer to conform to the inside of the hull, while preventing the transducer locknut from unwinding.
4. Route the transducer cable through the hole in the hull. Do not pull on the cable as this may cause internal damage to the transducer by causing an internal wiring short and require a new transducer to be installed.
5. Apply a good grade of underwater marine sealant (polysulphide compound) to the flange of the transducer. Use enough sealant so that it beads out around the transducer as you tighten from inside of the hull.
6. Put the nut on the transducer from the inside of the hull. If nylon, hand tighten only. If bronze, tighten with a wrench.
7. Clean off any excess sealant from around the transducer.

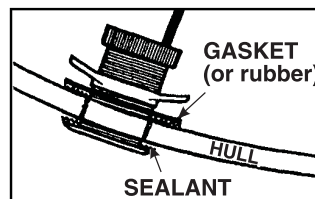
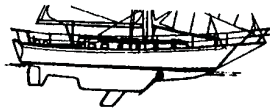

**IMPORTANT: AFTER LAUNCHING THE BOAT, BE CERTAIN TO CHECK THE TRANSDUCER LOCATION FOR LEAKS.**

## INSTALLATION: POWERBOAT BRONZE TRANSDUCERS

This style of transducer is popular as a replacement transducer since it was the primary style used on older boats and the stem will fit the same size hole as the previous defective or obsolete transducer. In order to provide good, steady readings, it requires the use of a fairing block. Without a fairing block, the large portion of the transducer is unprotected and runs the risk of being hit off by objects in the water. Fairing blocks are best made out of hard wood such as oak. The shape of the block will be determined by the shape of your hull and the style of transducer you choose.

- WOODEN BOATS require the use of a bronze transducer or bronze fittings due to the fact that when the boat is out of the water, the wood dries. When the fitting is installed and the boat returned to the water, the wood will swell and possibly crack a nylon type of transducer. Therefore, bronze is required for all wooden boat installations.

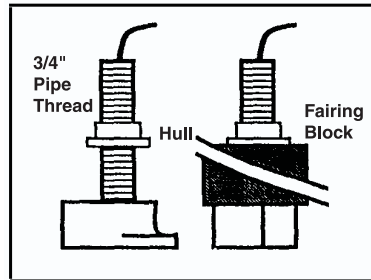

### HOW TO INSTALL POWERBOAT BRONZE (STEM TYPE) TRANSDUCER:

1. Drill a 1/8" pilot hole in the preferred transducer location. Reference previous section on determining the best location for your type of boat.
2. Drill a hole "slightly" larger than the stem of the transducer. Be careful not to make it too large as you will run the risk of water leaking into the hull.
3. Cut the fairing block to the shape of your hull and insert the cable and stem of the transducer through 1/2 of the fairing block.
4. Apply a good grade of underwater marine sealant (polysulphide compound) to the flange of the transducer and to the surface of the leveling block where the block touches the outside of the hull. Apply enough sealant so that it will bead out around the transducer as you tighten the transducer nut.
5. Put the remaining 1/2 of the fairing block on the inside of the transducer along with sealant next to the hull. Tighten transducer nut lightly with a wrench.
6. Clean off the excess sealant from around the transducer.

**IMPORTANT: AFTER LAUNCHING THE BOAT, BE CERTAIN TO CHECK THE TRANSDUCER LOCATION FOR LEAKS.**

  
**INSTALLATION: INSIDE THE HULL TRANSDUCERS**

This type of transducer is very popular since it does not require the drilling of a hole such as the through-the-hull transducer. However, you should consider the disadvantage due to the possible loss of sensitivity which could cause a measurable depth loss in terms of maximum depth capability. The success of inside the hull installation is also greatly dependent upon the purity of the hull directly below the transducer and the type of hull.

When performing an inside the hull installation, you must use the special INSIDE THE HULL TRANSDUCER since internal to the housing is a transducer crystal which is wider in inside diameter than other styles of transducers and is designed to transmit the pulse through the hull. Do not attempt to use a transom mount transducer as the crystal is too small to insure optimum instrument results.

Make sure that the transducer mounting location is at a point where a minimum of air bubbles occur beneath the installation location. For example, do not choose an area above a lifting strake because this is an area where air travels underneath the hull and could cause erroneous readings or not allow the pulse to transmit and/or be received back to the unit.

**DO NOT USE INSIDE THE HULL MOUNTING ON ALUMINUM, BALSA CORE OR WOODEN HULLS, OR HULLS WHERE THE DEAD RISE ANGLE IS MORE THAN 15.**

  
**HOW TO INSTALL INSIDE THE HULL TRANSDUCER:**

1. Select a relatively "thin" area of the hull. Avoid any built up areas that have been added to strengthen the hull.
  2. The transducer must be below the waterline and in an area where it will always have water underneath its surface.
  3. Mount in an area as flat and horizontal as possible. The greater the angle (deadrise) of the hull, the greater the loss in sensitivity and maximum depth.
  4. We recommend that you perform a test to determine the accuracy of readings before permanently installing the transducer. Do this by either placing the transducer in a plastic bag of water or putting axle grease on the face of the transducer. Then try the unit in this location to ascertain the readings in shallow water and deep water.
  5. After finding the optimum location, sand and clean the installation surface until it is smooth. To insure a proper bond, clean and dry the bonding surface. Remove any oil residue on the surface and clean an area roughly 4 inches in diameter. Finish this cleaning process by wiping this area down at least twice with an acetone or lacquer thinner. **DO NOT USE ANY STRONG SOLVENTS IN CONTACT WITH THE PLASTIC OF THE TRANSDUCER SINCE SOME SOLVENTS WILL WEAKEN AND DESTROY THE PLASTIC.** Also make sure that the ambient temperature is above 60° F (15°C).
  6. **MIX THE TWO PART EPOXY SUPPLIED WITH THE TRANSDUCER FOR AT LEAST 3 MINUTES.** If this is not done, proper bonding of the transducer to the hull will not occur and false readings can be caused.
- 

7. Apply the mixture to the clean location on the hull and to the face of the transducer in a small amount.
8. Press the face of the transducer into the spot of epoxy and slowly rotate it  $\frac{1}{4}$  turn to remove any air bubbles and until the transducer is physically against the hull or with  $\frac{1}{4}$ " of the hull.

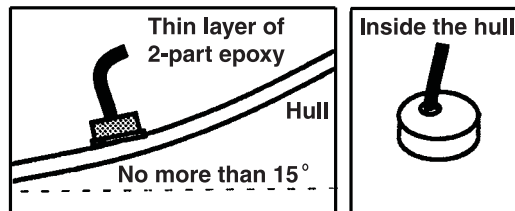

When the epoxy has cured, it should be permanently bonded to the hull and hard to the touch. Test the epoxy which extends out of the underside of the transducer with a screwdriver to insure that it can't be dented and is totally hard. Epoxy which is not hardened will eventually come up and cause improper readings.

## OPERATION:

## How to set the alarm

### HOW TO SET THE SHALLOW WATER ALARM

Located just below the LCD window are two keys labeled "DOWN" and "UP" Alarms. These keys are used to set the Shallow Water depth alarm so that it will alert you if you enter water shallower than your preset alarm.

To set an alarm, depress the "DOWN" key. You will note that the LCD will show an alarm depth of A03. Pressing the "DOWN" key continuously will cycle the alarm setting deeper by one foot increments from A03 through A10 feet (ie: 3, 4, 5, 6, 7, 8, 9, 10). After A10, alarm settings are by two foot increments (ie: 10, 12, 14, 16, 18, 20 feet). The alarm setting jumps by five foot increments (ie: A20, A25, A30). When you see a digital readout on the LCD preceded by an A, this is your ALARM depth.

To decrease the alarm setting, depress the "UP" key and the display will show these number in decreasing value so that the alarm is shallower. Several seconds after you depress either the "UP" or "DOWN" keys, the instrument will display the actual depth reading.

## GLOSSARY

A partial list of terms used is presented herein.

**BEAM ANGLE:** A transducer beam angle is shaped in an inverted cone (narrow at the top and larger at the bottom). Most of the energy from the instrument is reflected back to the transducer when it hits bottom. There are different beam angles for different purposes. Generally, narrow beam angles are used on digital depth sounders, medium beam angles for deeper depth, and wide angles for applications where there is a need to look at a larger area below the boat.

**GAIN (SENSITIVITY):** Gain is another name for sensitivity control. The deeper the water, the more gain you will require.

**RANGE:** The total depth capability, depending on bottom conditions. Maximum depth tends to decrease as the bottom becomes softer.

**THROUGH HULL FITTINGS:** Plastic through hull depth transducers should be mounted in fiberglass and metal hulls only. Plastic should never be used in wooden hulls as the swelling of wood may overstress the plastic housing. Do not use bronze housings in aluminum hulls since electrolytic corrosion will occur.

**TRANSDUCER:** All depth sounders emit ultrasonic sound signals that travel through water looking for a strong return echo (impulse). Inside the transducer is a crystal element that transmits as well as receives these pulses. The unit calculates the amount of time for the signal to travel to the bottom and return back to the transducer. It then converts this time into depth and displays it on the screen.

**TRANSDUCER FREQUENCY:** The rate at which the sonar vibrates. It is critical to installation that the frequency of the transducer and the frequency of the instrument be the same. Sonar instruments are designed to operate on a frequency which can provide different results such as shallow or deep water performance, etc. It is best not to have two of the same frequency transducers on the same vessel, unless you plan in advance for this type of installation with a Switch Box so that you can switch from one transducer to the other.

**TROUBLESHOOTING:**

**GENERAL OPERATION**

**SYMPTOM:** Unit does not turn on at all. No beep, no display.  
**CHECK:** Make sure the unit is actually receiving power. Check the inline fuse, and the circuit breaker panel on the boat. Make certain the unit is receiving 11 to 16 volts of CLEAN DC. Make sure the DC polarity has not been reversed. Check for corrosion on the power connector, and clean if necessary.

**SYMPTOM:** "0.0" FLASHING in display window.  
**POSSIBLE REASON:** The unit is not receiving an echo which could be caused by a variety of reasons.

1. As previously described, this could mean that the Sensitivity Adjustment was turned too much in one direction, actually squelching out the echo.
2. The transducer could be defective, therefore, not transmitting or receiving echoes.
3. The installation of the transducer could be incorrect, thereby not allowing a pulse to be transmitted or received.
4. The unit could be defective and need to be returned to the factory for repair.

**HOW TO SOLVE:**

1. Correctly adjust the Sensitivity Control so that the number in the display window start to appear and are reading the correct depth.
2. Try a "known good" transducer hooked up to the gauge and see if the depth appears in the window. It is important to "wet" the transducer immediately before immersing in the water.
3. Check to insure that the transducer is installed as per the instructions in this manual. Inside the hull transducers must be properly bonded and attached to the hull as described in the section on inside the hull mounting or must be properly installed by the Boat Manufacturer if the equipment was installed at the boat factory.
4. If all of the above tests resulted in "0.0" remaining in the window, return the unit for repair.

**SYMPTOM:** Unit not reading properly at high speeds, causing high random numbers at high RPM's.

**REASON:** There are three basic types of installations: inside the hull, through the hull, and transom mount. Generally, this situation is attributed to the location and installation of the transducer. A great deal of air is flowing over the face of the transducer and is inhibiting the unit from receiving the correct bottom reading. Cavitation (locked on bubbles) either on the face of the transducer or on the under belly of the boat are preventing the unit from displaying the true depth.

**HOW TO SOLVE:** Refer to the pages in this manual, along with the drawings for your particular boat on the proper installation technique. If this is a transom mount transducer, it may require that the transducer be adjusted lower in the bracket so that it extends further under the bottom of the boat and is allowed a clean flow of water. It could also require that the transducer and/or bracket be relocated to achieve a clean, smooth flow of water over the face of the transducer.

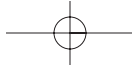

**SYMPTOM:** Unit smoked.

**REASON:** A wire from the transducer was accidentally plugged into the Remote Alarm terminal located next to the power + or - terminals.

**HOW TO SOLVE:** Return the unit to the factory for repair.

**SYMPTOM:** Transom mount transducer breaking where the mounting bracket attaches to the transducer.

**REASON:** This occurs if the transducer is installed under a fuel overflow vent OR if an adhesive such as LOCKTITE was used to bond the hardware onto the transducer mounting bracket.

**HOW TO SOLVE:** The transducer has probably been permanently damaged and is non-repairable. Before installing a replacement transducer, be sure and move the bracket. The adhesive or petrol has eaten into the plastic and cannot be repaired.

**SYMPTOM:** A30 or A03 reads out permanently on the display.

**REASON:** The only way this could occur is if a lug from a transducer wire was accidentally connected to either the Alarm Up/Down terminal and power was applied.

**HOW TO SOLVE:** Unfortunately, permanent damage has been done to the main surface mount "chip". The instrument head only must be returned for repair.

**SYMPTOM:** Unit showing "88.8" in the window.

**REASON:** This failure indicates a logic circuit failure that was probably caused by a poor solder connection, lack of solder or improper wiring.

**HOW TO SOLVE:** Return the unit to the factory for repair.

**TROUBLESHOOTING:**

**SHALLOW WATER SENSITIVITY**

The Shallow Water Sensitivity controls a circuit in the depth sounder that effects the first 10 ft. of water. It alters the system's response time in this area only and can be used to compensate for installation imperfections.

For example:

**SHALLOW READINGS:** If your instrument occasionally displays random, false shallow readings such as 3.1, 2.8, and 4.3, you may need to adjust this control.

**DEEPER READINGS:** If your unit is reading false echoes which are deeper than the actual depth, you may not have enough sensitivity which can also be corrected by using this control.

**"O.O" READINGS:** Adjusting this control in extremes too far in either direction, could effect your readings. For example, if the adjustment is made TOO MUCH, it could actually cause the unit to give a "O.O" reading at a deeper depth. The true depth could be 30 ft. and if the control is too extreme in a counter clockwise direction, the readout could be "O.O".

This adjustment fine tunes the installation of your gauge to the location of the transducer on your boat and to the waters where you do your boating. It is typically an adjustment that made by the boat owner since it is performed while the boat is in the water.

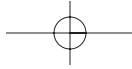

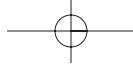

Each depth gauge is tested at the factory with a transducer located in a water tank and the Shallow Water Sensitivity is factory pre-set. However, during shipment, after installation or in your local waterways, it may require that you perform this minor adjustment so that it performs to its maximum potential on your boat.

With inside the hull transducer installations it is especially important to perform this adjustment, It is impossible to control the many types of hull configurations on the many varieties of boats available today. Since fiberglass hulls are generally hand-layed, the hull thickness can vary from boat-to-boat even though they may be the same model. Thickness of the fiberglass, combined with the many types of bottom conditions (sandy, rocky, muddy), can affect the readings on your digital depth sounder. This control enables you to more precisely tune your gauge so that the unit reads properly. Unless major changes take place in your boating environment, you should not need to adjust this setting again.

#### WHEN TO USE LESS SENSITIVITY SHALLOW READINGS:

When your instrument displays a series of random, shallow readings (3.5, 2.9, 4.1) when the actual depth is greater.

**HOW TO PERFORM:** When looking at the rear of the instrument, this adjustment is made in a clockwise direction. (This control operates much like the volume control on a radio. If you turn it all the way down, you cannot hear the music. Turning it up too far, makes the music blare and sound out of tune.) Turning the sensitivity control too much can actually "squelch" out the transmit pulses and the return echoes and will result in a "0.0" reading in the display window. **NOTE:** When making this adjustment, turn the control no more than 1/16th of a turn at a time and then wait 3 to 4 seconds before making the next adjustment turn.

#### WHEN TO USE MORE SENSITIVITY - DOUBLE ECHOES READINGS TOO DEEP:

When your instrument is displaying depths that are actually greater than the actual depth. For example, if you are in 6 ft. water and you turn this control too far in the less sensitivity direction, you may see "12.0" appear in the LCD window. This is very dangerous since you will actually be operating the boat in shallower water than that which is displayed. Caution should be exercised to locate the Sensitivity Control somewhere between both ends of the rotation.

**HOW TO PERFORM:** By rotating the control in a counter-clockwise direction (when looking at the rear of the instrument), you can increase the sensitivity of the gauge to the first 10 ft. water. Increasing this adjustment too much in the MORE SENSITIVITY direction can cause a "doubling" of the actual depth. **NOTE:** When making this adjustment, turn the control no more than 1/16th of a turn at a time and then wait 3 to 4 seconds before making the next adjustment.



**CARE AND MAINTENANCE:**

- Never spray directly with a hose or otherwise submerge your unit.
- Never use harsh cleaners or solvents (gasoline, window cleaner etc.) to clean your instrument or the transducer or paddle wheel.
- Do not use Loctite® on any plastic parts like the transducer since it will disintegrate the material and destroy the plastic. This kind of damage is not covered under warranty.

**SPECIFICATIONS:**

Depth Ranges:	Minimum Range	Maximum Range
	2.5 feet	200 feet
Alarms:	Shallow Water	
Transducer Frequency:	200 KHz	
Transducer Beam Angle:	Standard beam is 27 degrees	
Transmit Power:	600 Watts Peak to Peak	
	70 Watts RMS	
Power Requirements:	11.5 - 16 volts DC	Draws .25 amps Max
Window Size:	1-3/8" Wide x 3/4" High	
Physical Dimensions:	2" round x 3-1/4" Deep	

**ALL SPECIFICATIONS SUBJECT TO CHANGE WITHOUT PRIOR NOTICE**

**SPARE PARTS LIST:**

Stainless Steel Kick Up Bracket	652-013	(option)
---------------------------------	---------	----------

**REPLACEMENT TRANSDUCERS - 200 KHz**

Transom mount	650-2706
Low Profile Nylon	650-5406
Power Boat Bronze	650-1306
Low Profile Bronze	650-5606
Inside the Hull	650-2906

**APPENDIX**

**PRESIDENT LIMITED WARRANTY**

The seller makes no warranties, agreements, or representation of any kind concerning goods sold; and the goods are sold without any warranty of merchantability or fitness for any particular purpose or use. Buyer shall not be entitled to recover any incidental or consequential damage, a those terms are defined in the California Commercial Code; and any liability PRESIDENT may have with respect to the goods shall be limited to the repair of the goods sold.

PRESIDENT products are thoroughly inspected and tested before shipment from the factory. PRESIDENT products and all their parts are warranted to be free of defects in workmanship and material for one full year from the date of purchase or within a maximum period of eighteen (18) months from shipments from the factory. This warranty is extended to and is solely for the benefit of the "Original Consumer Purchaser".

All units in need of repair will be serviced and repaired without charge to the purchaser during the above mentioned period in accordance with the following terms and conditions:

1. The product is returned "freight Prepaid" to:  
PRESIDENT, 4700 Amon Carter Blvd., Fort Worth, TX 76155 USA  
For your protection it is advisable to insure the parcel against loss or damage.
  2. "Proof of Purchase" date has been established by completing and returning the Warranty Registration Card to PRESIDENT within ten (10) days of the date of purchase. A copy of the sales receipt can be provided by the purchaser when the unit is returned for repair.
  3. Information is provided regarding the nature of the failure outlined.
- This warranty does not cover defect or damages caused by unauthorized service nor damage through accident, misuse, or abuse. The owner is also responsible for the necessary maintenance and installation in accordance with instructions provided in this Owner's Manual.
  - Any costs incurred with transducer or impeller replacements other than the cost of the transducer or impeller itself, is specifically excluded from this warranty.
  - PRESIDENT shall not be liable for damages resulting from the use and operation of this product.

PRESIDENT reserves the right to make changes or improvements from time-to-time without incurring the obligations to install such improvement on equipment previously manufactured.

Some states do not allow the exclusion of limitations of incidental or consequential damages, therefore, the above limitations or exclusions may not apply to you.. This warranty gives you specific legal rights and you may have other rights which vary from state to state.

**APPENDIX**

**OUT OF WARRANTY - FLAT RATE CHARGE**

PRESIDENT will repair and/or recondition the instrument to its original operational standards. Upon completion of repair, PRESIDENT offers its original Limited Warranty to the instrument for a period for 90 days after the date of repair.

Exceptions to the Flat Rate Charge - Out of Warranty policy are as follows:

1. Replacement of the Liquid Crystal Display (LCD).
2. Cases, front panels, knobs, brackets and hardware associated with the assembly of the instrument.
3. Transducers, impellers, and power cords.

This program does not cover defects or damages caused by unauthorized service, nor damages through accident, misuse, or abuse. The owner is responsible to provide reasonable and necessary maintenance in accordance with instructions provided in this Owner's Manual and to use common sense regarding storage in extreme weather conditions.

Service performed by PRESIDENT for instruments Out of Warranty will be charged at a Fixed Rate established at the beginning of each calendar year.

- The Flat Rate Charge for 1991 for the President LTD 260 is \$59.00 which will be charged for each repair incident occurring in the year.

Rates are subject to change without prior written notice.

Software Updates may be available in the future at a nominal rate. The instrument will be updated to the most current version of software available and a new Owner's Manual will be provided to the user.

For your protection, it is advisable to insure the parcel against loss or damage. Shipping charges are the responsibility of the owner.

PRESIDENT  
4700 Amon Carter Blvd.  
Fort Worth, TX 76155

PHONE: (800) 586-0409

FAX: (800) 323-2641

Checking on the Status of Repairs:  
PHONE: (800) 586-0409

**PRESIDENT**

Corporate Offices  
4700 Amon Carter Blvd.  
Fort Worth, TX 76155  
Facsimile: (817) 858-3311  
Telephone: (817) 858-3300

**PRESIDENT**

Service Facilities:  
4700 Amon Carter Blvd.  
Fort Worth, TX 76155  
Facsimile: (800) 323-2641  
Telephone: (800) 586-0409

Part Number: 103-014  
©1991, 1996 President

